

AcquaSaver



Water Diversion Valve

Hydraulically Operated
Solid Brass Construction
Full Flow



WaterMark
ATS 5200.477
WMK 60075
AGA

AcquaSaver

AcquaSaver is an automatic hydraulically operated mains to rainwater changeover valve. Ideal for rainwater harvesting which switches from mains to tank whenever tank water is available and automatically defaults to mains in the event of a power or pump failure.

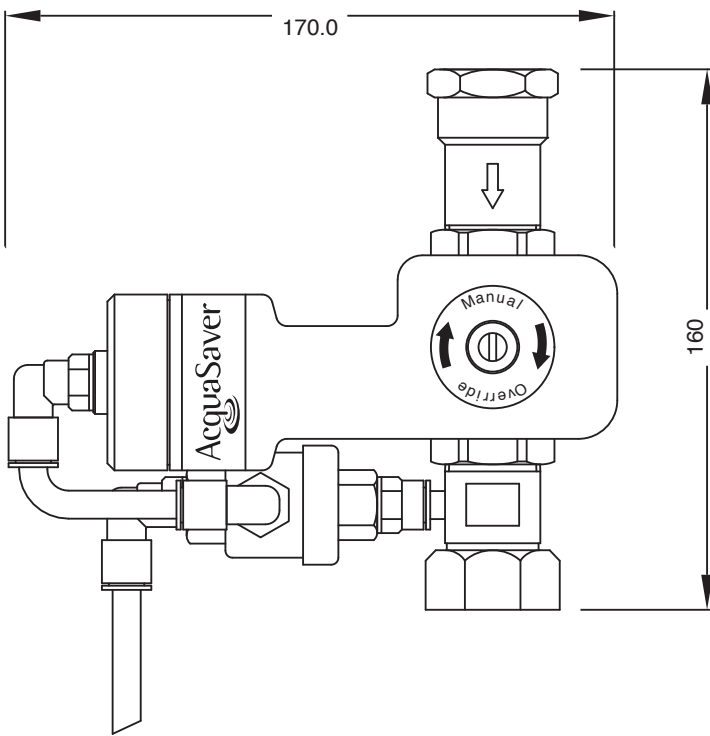

Specifications

Max mains Pressure 600kpa
Max pump Pressure 800kpa
Max Flow Rate 100Lpm
Rainwater Inlet 25mm 1" BSP F
Mains Water in 20mm 3/4" BSP F
Weight 2.2Kg
Complies to AS/NZS 3500.1
when installed by a licensed
Plumber.

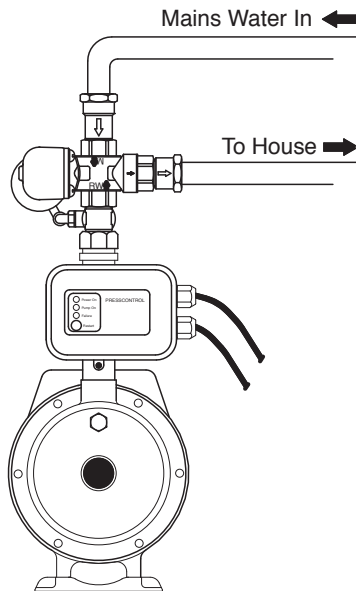

Features

- Easy to install
- Full flow
- Solid brass- Weather proof- Built to last!
- Does not require regular maintenance
- No electrical components
- No electrical consumption
- Suitable for any surface pressure pump or submersible pressure pump
- Can be mounted in any position
- Dual check valve for backflow prevention (WATERMARK APPROVED)
- Patented design
- Manual override
- 2 Year warranty
- Can be positioned any distance from the pump
- Can be mounted directly onto the pump



WaterMark
ATS 5200.477
WMK 60075
AGA

Note : For pumps without Automatic restart facilities, a float switch will be required.
Part No: AKMS 50324

available from:

 **Brown Brothers
Engineers
Australia Pty Ltd**

Delivering Pumping Solutions

Branches in Melbourne, Sydney and Brisbane